



51.2V314Ah-HV Battery connects with DEYE inverter

SUN-29.9~50KSG01HP3.

第一部分：组装电池系统。

Part one : install battery system.

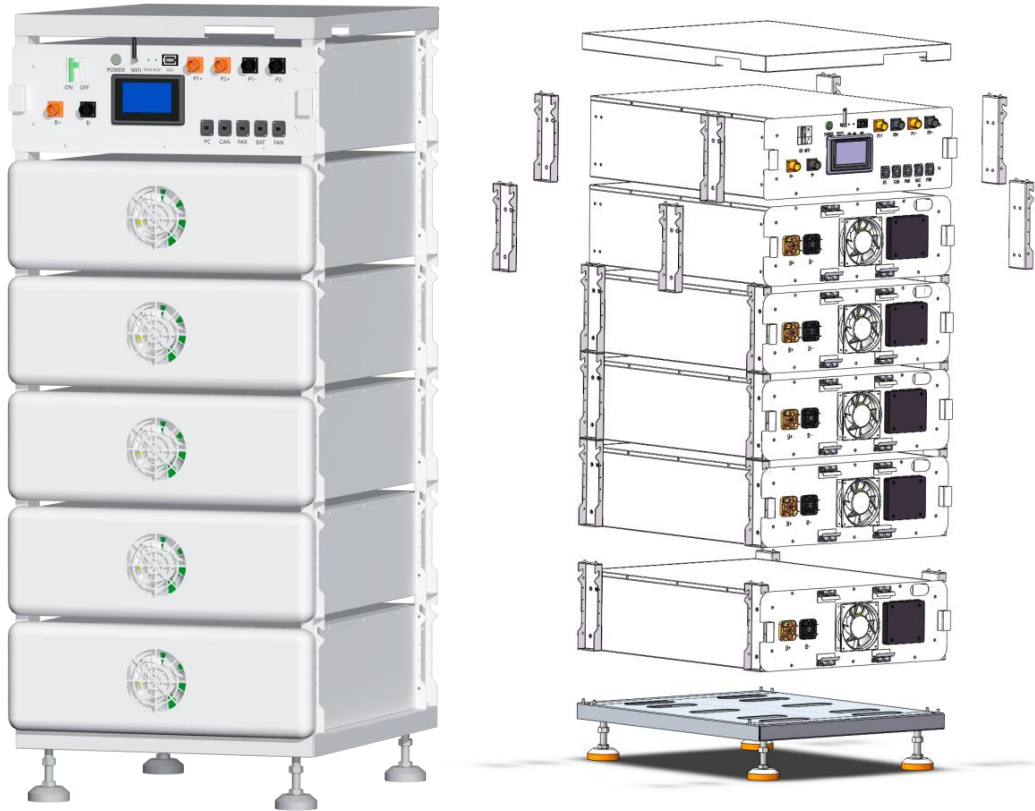

1. 组装好承重底座；

Assemble the load-bearing base.

2. 将电池组和主控模块逐个装上四个堆叠钣金；

Install the battery pack and the main control module onto the four stacked metal sheets one by one.

3. 从下到上，对准限位孔组装电池组，最后装上主控和顶盖；

Assemble the battery pack from bottom to top by aligning the positioning holes, and finally install the main control unit and the top cover.

4.接好电路之后，再装上前盖板。

After connecting the circuit, install the front cover plate.

第二部分：连接电池电路。

Part Two: Connecting the Battery Circuit.

1. 如图连接电池电源线。

Connect the battery power cables as shown in the diagram.

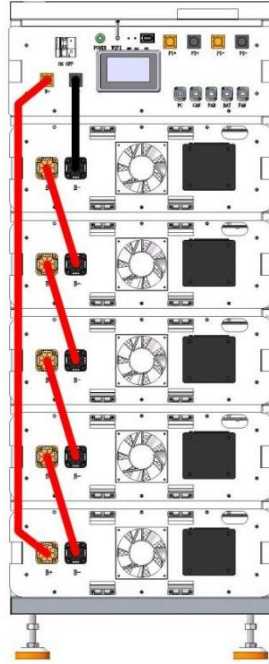

2. 依次连接电池模块通讯线，接入主控BAT通讯端口。

Connect the battery module communication cables in sequence, and plug them into the main control BAT communication port.

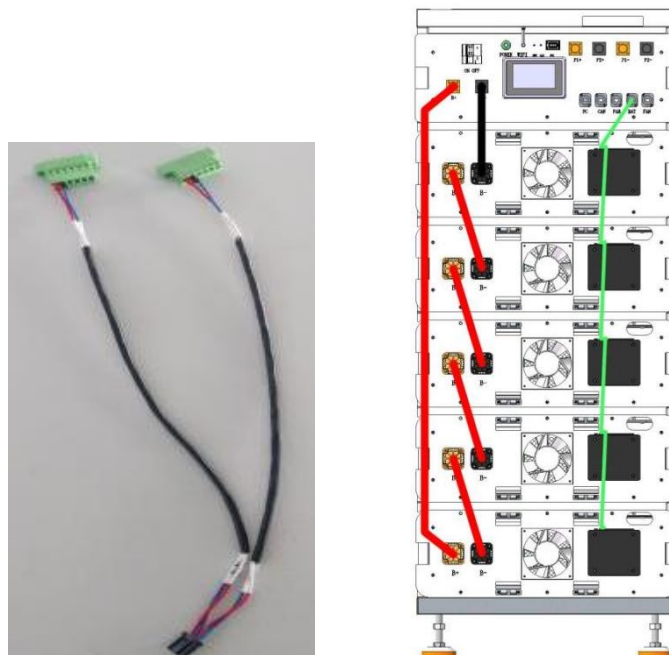

3. 连接散热风扇供电线。

Connect the fan power cables.

电池模块风扇配件上自带的两个红色插头上下连接另一个电池模块风扇，最后接入主控上FAN端口。

The two red connectors on the battery module fan accessories should be connected to another battery module fan, and finally plugged into the FAN port on the main control unit.

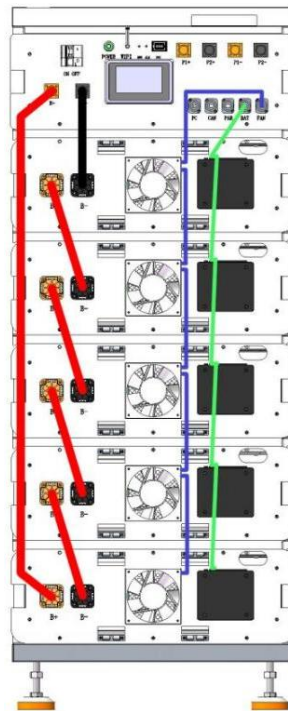
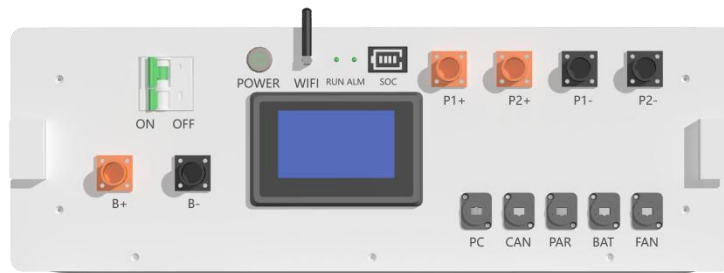

第三部分：连接和设置逆变器。

Part three : connect and set the inverter.

注:由于 Deye 29.9K~50K 系列的逆变器可以连接两组电池，每组电池的最大输入和输出电流被限制在 50A。-单电池模块容量为 10kWh 或以上，支持最大放电电流 $\geq 100A$ 。为了提高电池供电的功率并节省储能成本，我们建议配置并联分流。(即，将一组电池连接到逆变器的两组接口)

Note: Because Deye 29.9K~50K series inverters can be connected to two sets of batteries, the maximum input and output current of a single set of batteries is limited to 50A. single battery module with a capacity of 10 kWh or above supports a maximum discharge of 100A or higher. In order to increase the power of battery power supply and save energy storage costs, we recommend configuring parallel shunting. (i.e. connecting a single set of batteries to two sets of interfaces of the inverter)

1.在逆变器设置菜单里，保持电池模式为锂模式，勾选“Parallel bat1&bat2”。

keep the Batt Mode on Lithium,select “Parallel bat1&bat2” from the Inverter Battery Setup Menu.

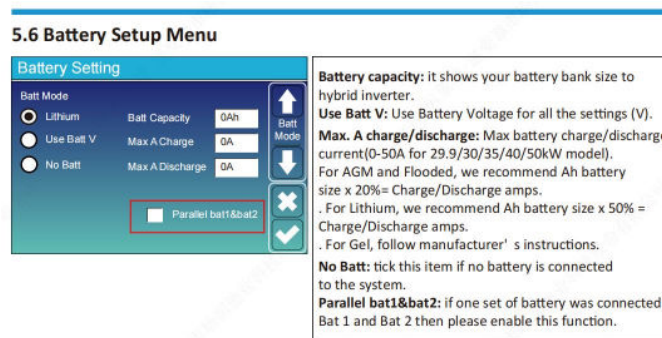

2.连接电源线。电池主控上的 P1+、P1-连接逆变器的 BAT1 电源口，电池主控上的 P2+、P2-连接逆变器的 BAT2 电源口。（此方式适用于单套电池提高功率，节省储能成本）

Connect the power cord. The P1+ and P1- on the battery main module should be connected to the BAT1 power port of the inverter, and the P2+ and P2- on the battery main module should be connected to the BAT2 power port of the inverter. (This method is applicable for increasing power with a single set of batteries and saving energy storage costs.)

3.连接通讯线。电池主控上的 CAN 端口连接逆变器的 BMS1 端口。

Step 3. Connect the communication line , connect the CAN port of the battery main module and the BMS1 port of the inverter.